

Slider Bed Belt Conveyor (SB)

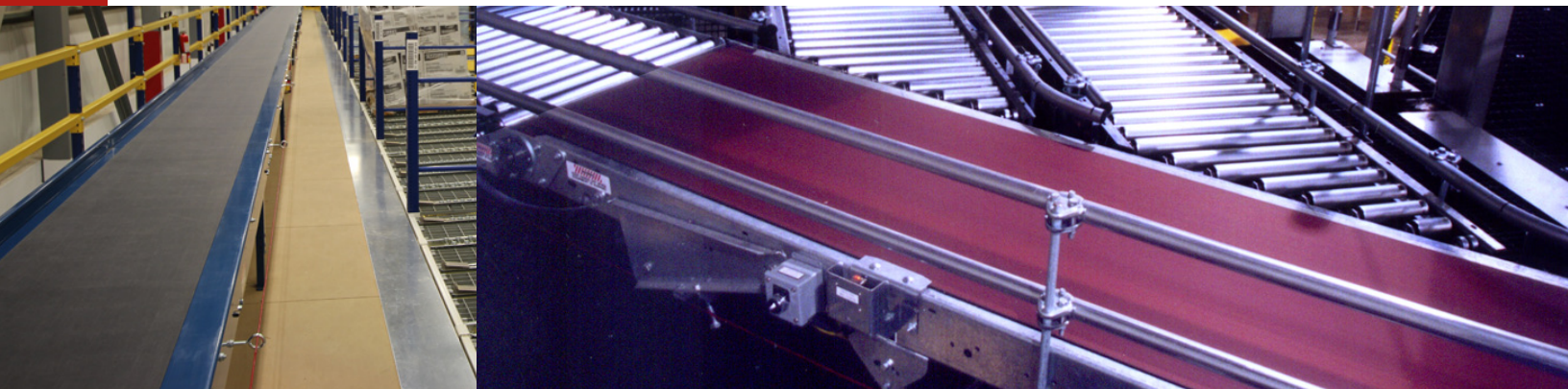

All of the advantages and benefits that make a big difference in durability and performance are built into each facet of Automotion's pre-engineered conveyor components.

Automotion's Slider Bed Belt Conveyor makes it easy to transport a wide variety of product shapes and sizes on level surface applications as well as in incline and decline applications. They are capable of handling a vast range of products in weights up to 100 pounds per foot. Automotion's Slider Bed Belt Conveyors are well supported, stable, quiet running, versatile and economical. These components feature adjustable power feeder and nose-over units. They are available in multiple widths, offer a variety of drives and take-up options and are sized to meet your requirements. Automotion's Slider Bed Belt conveyors use C-Faced motors which provide adjustability and variability via reducers to meet speed requirements. All mechanical operations run smoothly and quietly.



Mechanical Characteristics

Bed Section

5-1/4" Deep x 12 Gauge frame in 6" increments between 12" and 144".

Galvanized Belt Return Rollers

1-7/8" Diameter, 16 Gauge, carrying rollers with 7/16" hex axle on nominal 6' centers.

Drives

6", 8", or 10" Center Drives and 6" or 8" End Drives. Lagged pulley with automatic spring take-up on center drive. 3/4 HP to 5 HP 230V-460V/3-Phase/60Hz. "C" face TEFC motor with reducer. Speed range is 60-320 FPM.

Terminal End

4", 5" or 6" Diameter plain pulley with pop-out roller.

Belting

Type 1 Friction Surface X Bare Surface.

Axle Isolators

Specially designed conductive plastic insert isolates return roller axles from the conveyor frame to reduce noise and prevent wear.

Technical Details

Section View

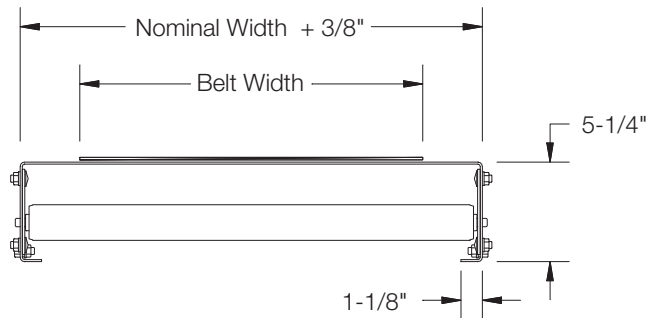

Elevation View

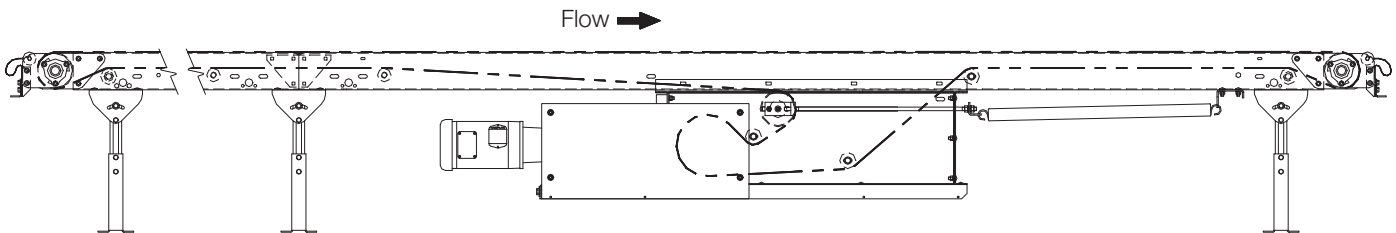

Specifications

Typical Applications

- Transportation
- Elevation Changes
- Sortation
- Brake Spacer Belts
- Trash Conveyor
- Pick Belts

Live Load Capacity

Up to 100 lbs/ft. depending on width, roller centers, supports, etc.

Nominal Widths:

18", 24", 30", 36", 42" and 48"

Standard Belt Widths:

14", 20", 24", 30", 36" and 42"

Options

- Take-Ups, Guard Rails, and Supports
- High Speed Rollers (std. over 180 FPM)
- Power Take-Off Units
- Drop Kit
- Bottom Covers
- Terminal End Covers
- Pop-Out Roller at Terminal End
- Punched for Top Mount Guard Rail
- Cog Belt Drive
- Powder Coat or Galvanized Finish